

To: **NASR Pharmaceutical Co.**

Tube Labeling Machine
FM-TPT-100
Technical Specifications



The People's Republic of China
HENAN FAIR MACHINERY CO.,LTD

河南费尔进出口贸易有限公司
Henan Fair Import & Export Trading Co., Ltd.



1. Usage:

It is suitable for flat labeling or self-adhesive film on various items, such as books, folders, boxes, cartons, etc.

The replacement of the labeling mechanism can be applied to labeling on uneven surfaces, and is widely used in flat labeling of large products. Labeling, labeling of planar objects with a wide range of specifications.

2. Main performance and features

2.1 Wide range of applications.

It can meet the product flat labeling and self-adhesive film with a product width of 30mm ~ 200mm, and the replacement of the labeling mechanism can meet the uneven surface labeling.

2.2 High labeling accuracy.

The servo motor drives the label delivery, and the label delivery is accurate; the design of the label tape detour correction mechanism ensures that the label does not deviate from the left and right during the label traction process; the eccentric wheel technology is applied to the traction mechanism, and the traction label does not slip, ensuring accurate



label delivery.

2.3 Rugged and easy to adjust.

The three-bar adjustment mechanism is adopted to make full use of the stability of the triangle, and the whole machine is solid and durable; Switching between different products is made easy and time-saving.

2.4 Flexible application.

Can be single machine production or assembly line production, production site layout is simple.

2.5 Intelligent control.

Automatic photoelectric tracking, with no labeling, no labeling automatic label automatic detection function, to prevent missing stickers and label waste.

2.6 Touch screen operation interface.

All Chinese and English annotation and perfect fault prompts function, all kinds of parameter adjustment is simple and quick, easy to operate.

2.7 Powerful.

With production counting function, power saving function, production



number setting prompt function, parameter setting protection function, convenient production management.

3. Configuration list

Item	Product Name	Qty	Model	Brand
1	Touch screen	1	DOP-107BV	Delta (Taiwan, China)
2	PLC	1	DVP-16EC00T3	Delta (Taiwan, China)
3	Inverter	1	VFD002L21A	Delta (Taiwan, China)
4	Label Feeding Servo Motor	1	(750W)	Raynen (China)
5	Server Driver	1	KA05	Raynen (China)
6	Switching Power	1	PMC-24V035W1AA	Delta (Taiwan, China)
7	Mark Detection Sensor	1	GS61/6.2	LEUZE (Germany)
8	Detect object sensor	1	FS-N18N	Keyence (Japan)
9	Conveyor Motor	1	0.12KW/RV40 1: 20	ZD (Ningbo,China)
10	Press Label Motor	1	31K15RGN-C/3GN30 K	ZD (Ningbo, China)
11	Low-voltage Apparatus	1		Schneider (France)

Note:

The equipment in this scheme is standard equipment. If there are special requirements, the equipment can be upgraded or improved

4. Technical specifications:

Model	FM-TPT-100
Labeling speed:	20-120 pieces/min (related to material and label size)
Labeling accuracy:	±1.0mm (excluding material and label size)
Material size:	(L) 20-300 (W) 20-180 (H) 15-200mm
Label size:	(L) 20-200 (W) 20-140mm
Applicable label roll inner diameter:	φ76mm
Applicable label roll outer diameter:	Maximum Φ350mm
Overall size:	2000×650×1600mm
Voltage:	AC220V 50Hz/60Hz 1.2KW

5. Details Pictures

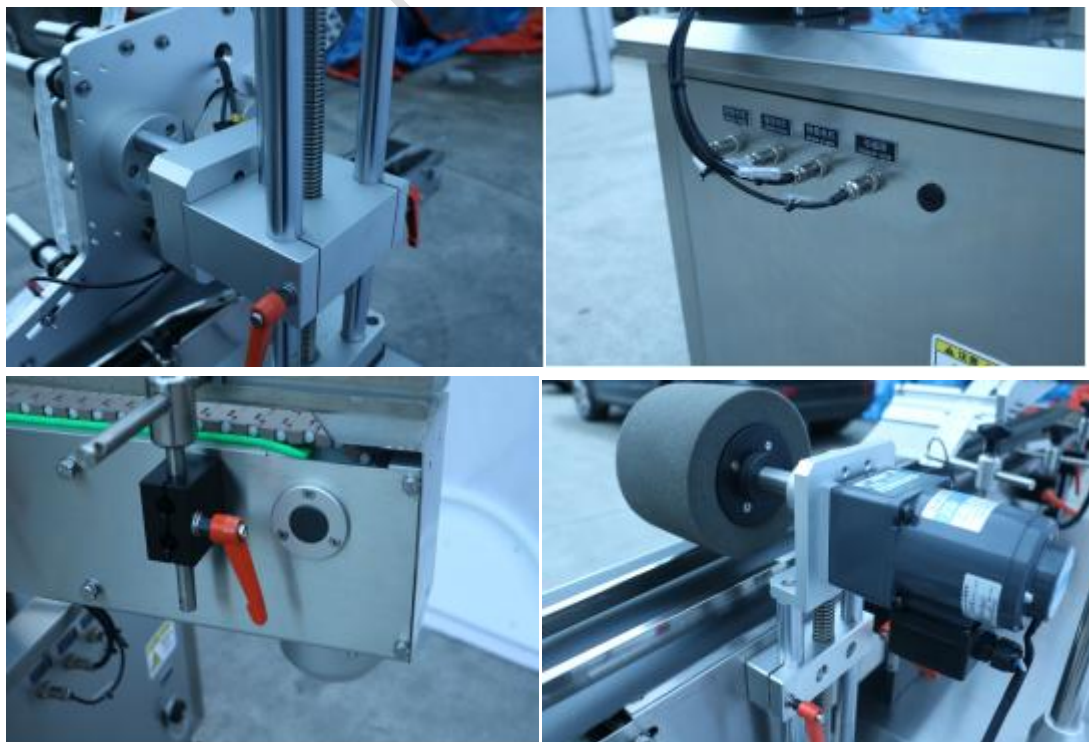

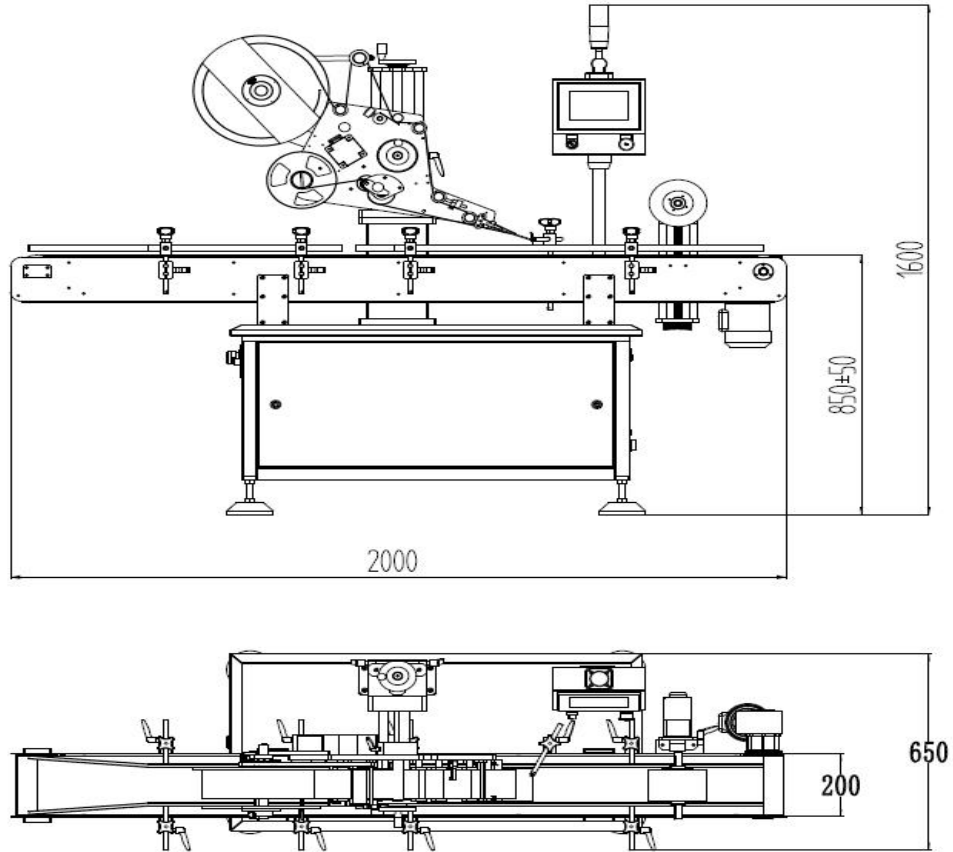

6. Labeling effect:



DESIGN BY

HENAN FIAR MACHINERY CO.,LTD